

ASSEMBLY DETAIL : SLIDING WINDOW

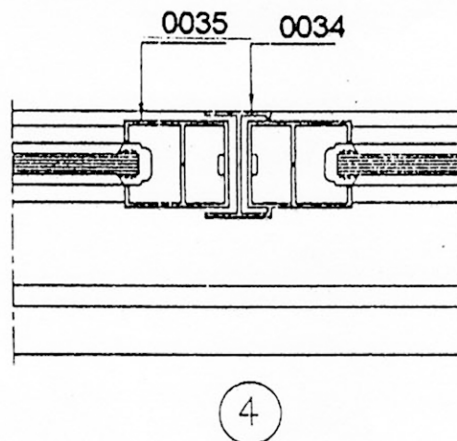

ASSEMBLY DETAIL : SLIDING WINDOW

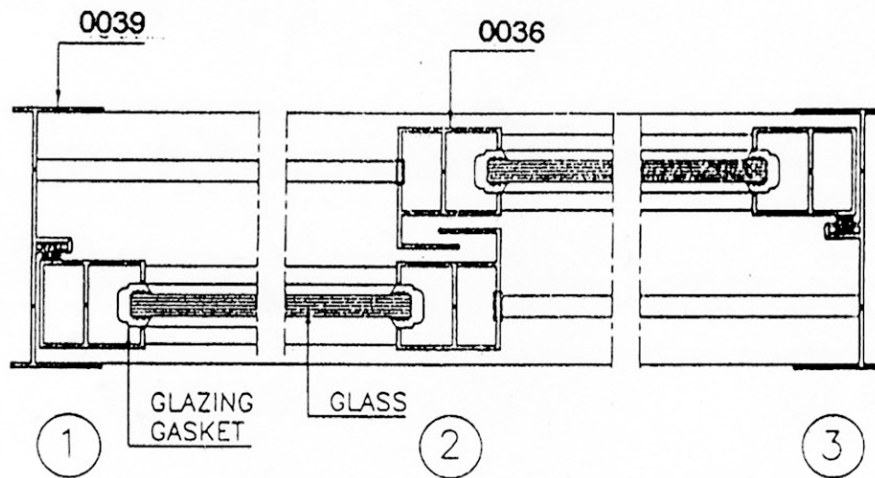
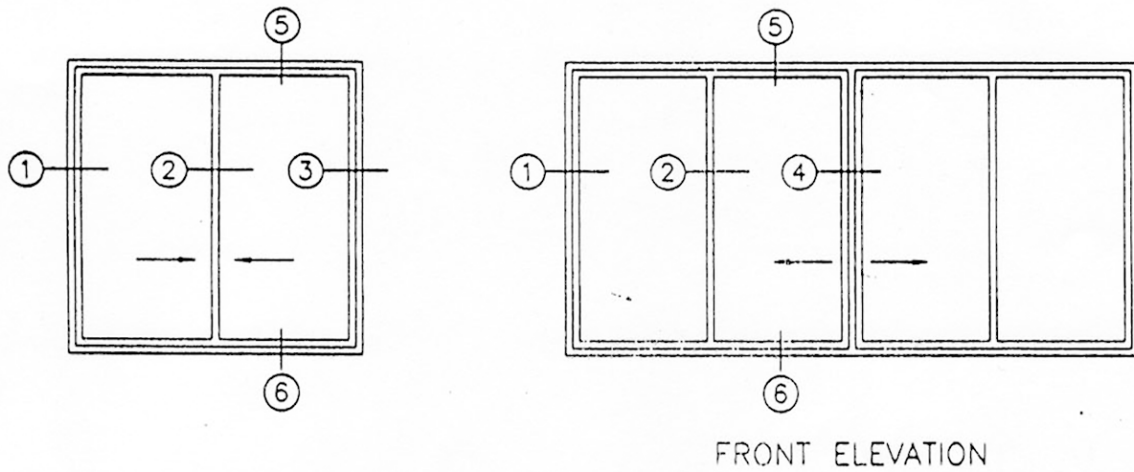
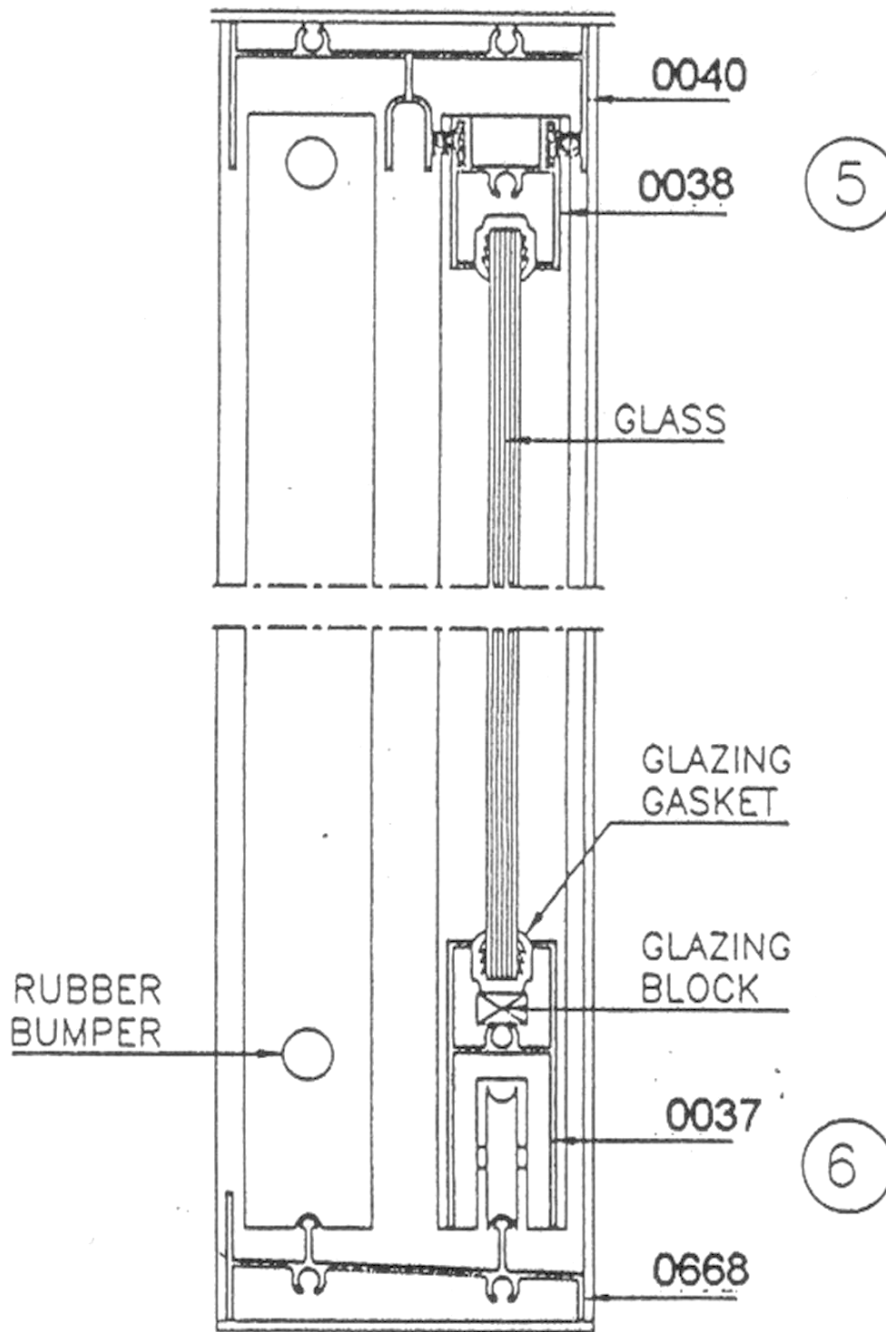

SLIDING WINDOWS

GROUP : 15

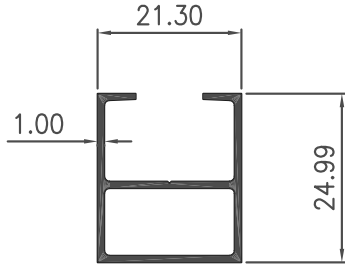

**Section No : 0035**

W = 0.265 KG/M  
P = 135.75 MM

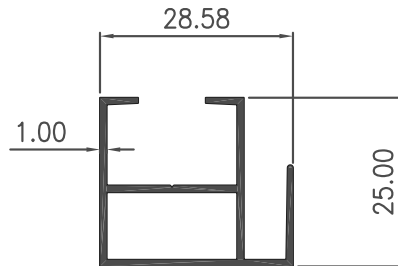

**Section No : 0036**

W = 0.316 KG/M  
P = 179.08 MM

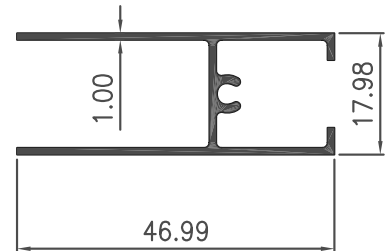

**Section No : 0037**

W = 0.343 KG/M  
P = 243.43 MM

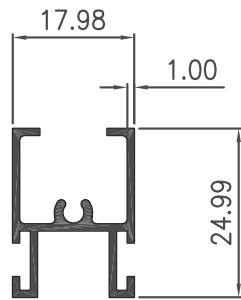

**Section No : 0038**

W = 0.258 KG/M  
P = 182.11 MM

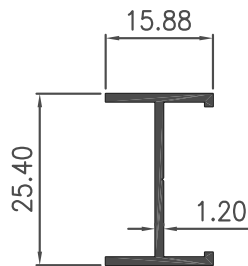

**Section No : 0041**

W = 0.182 KG/M  
P = 114.93 MM

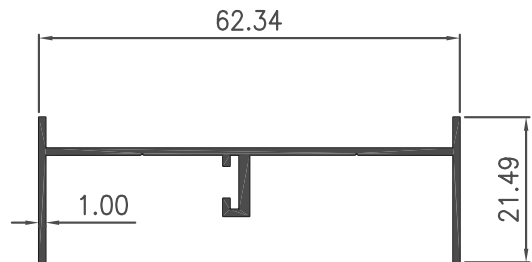

**Section No : 0039**

W = 0.332 KG/M  
P = 238.61 MM

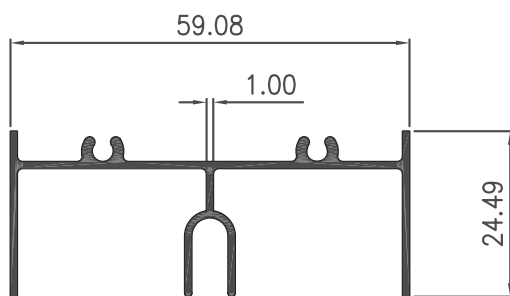

**Section No : 0040**

W = 0.447 KG/M  
P = 303.65 MM

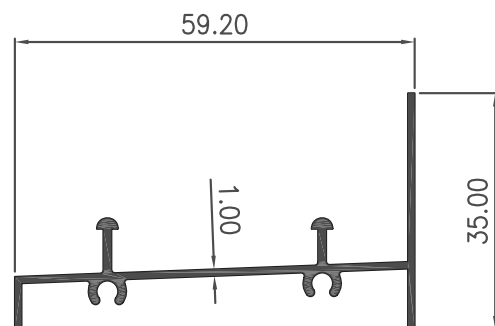

**Section No : 0668**

W = 0.384 KG/M  
P = 261.09 MM