

DIFUSSERS

GROUP : 26.A

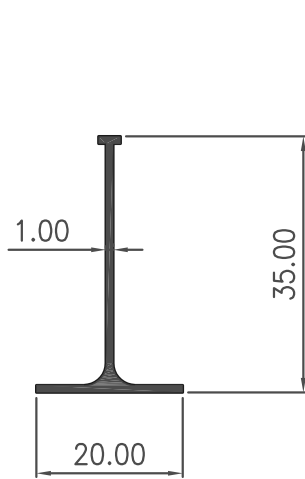

Section No : 1526

W = 0.162 KG/M
P = 111.42 MM

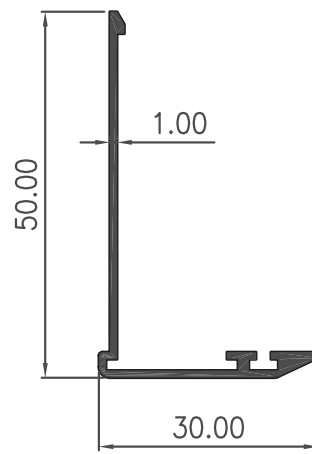

Section No : 1527

W = 0.257 KG/M
P = 178.31 MM

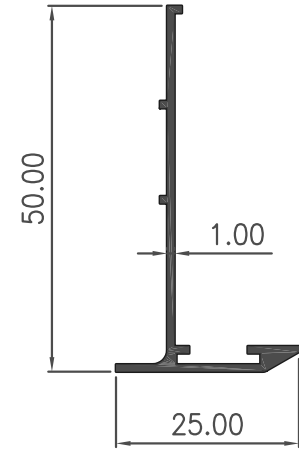

Section No : 1528

W = 0.240 KG/M
P = 165.31 MM

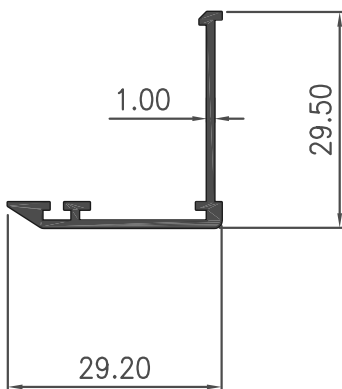

Section No : 1529

W = 0.202 KG/M
P = 138.25 MM

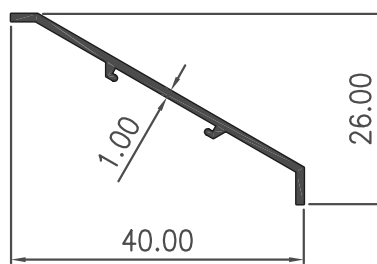

Section No : 1531

W = 0.147 KG/M
P = 110.33 MM

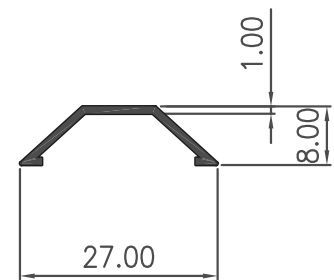

Section No : 1536

W = 0.093 KG/M
P = 69.88 MM

DIFUSSERS

GROUP : 26.B

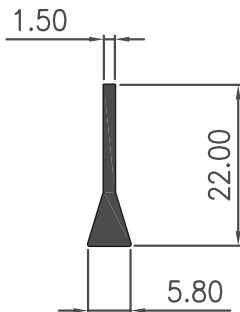

Section No : 1532

W = 0.133 KG/M
P = 51.77 MM

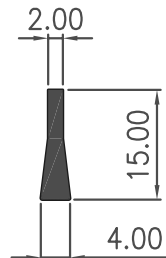

Section No : 1533

W = 0.104 KG/M
P = 35.95 MM

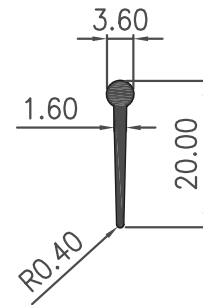

Section No : 1534

W = 0.080 KG/M
P = 43.29 MM

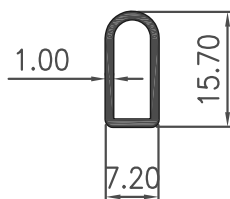

Section No : 1535

W = 0.105 KG/M
P = 41.85 MM

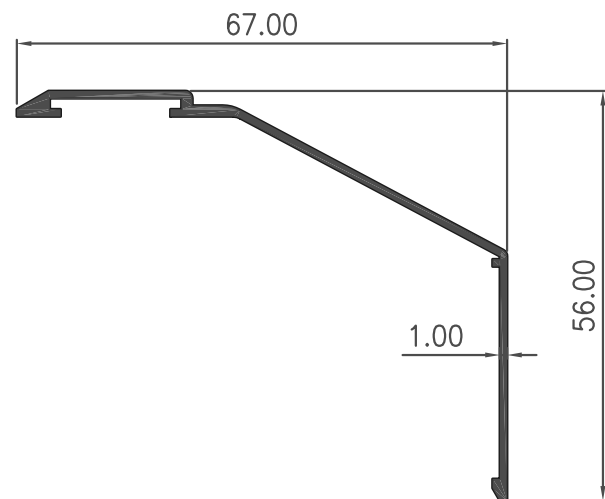

Section No : 1530

W = 0.334 KG/M
P = 228.47 MM