

ASSEMBLY DETAIL : SWING DOOR

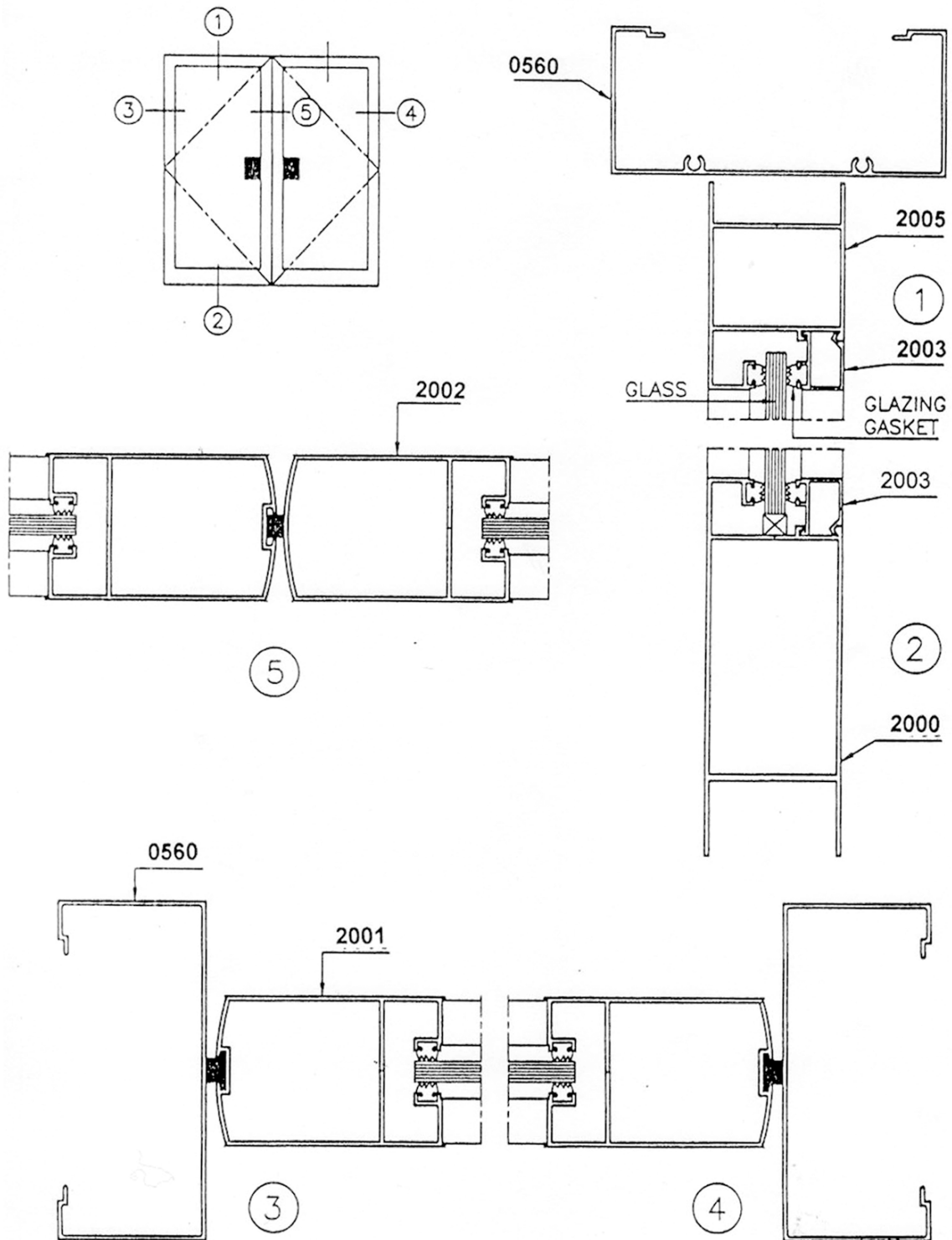

SWING DOOR

GROUP : 12.A

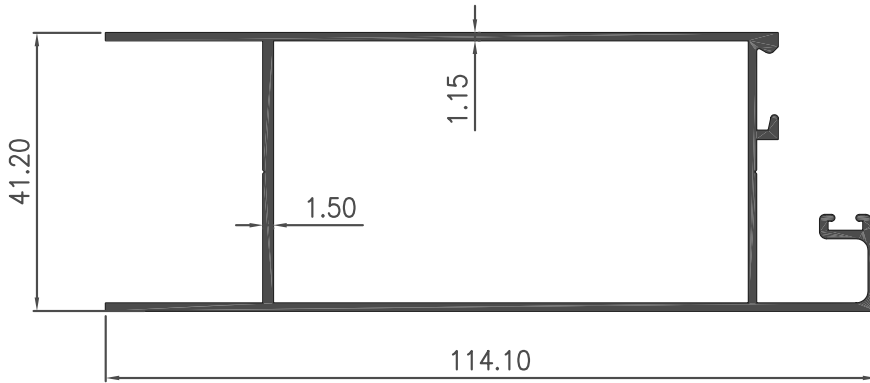

Section No : 2000

W = 1.054 KG/M

P = 420.32 MM

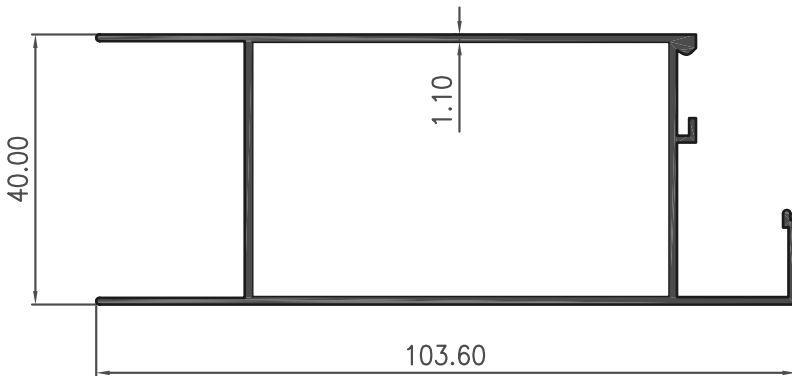

Section No : 2010

W = 0.854 KG/M

P = 373.85 MM

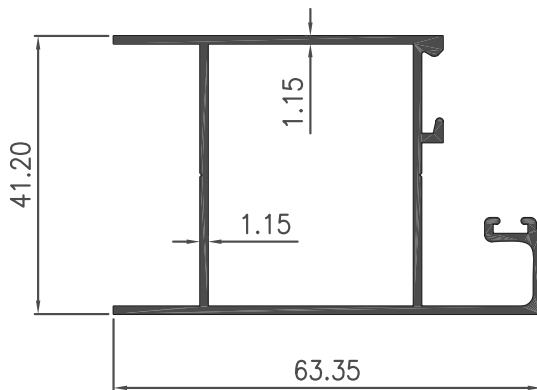

Section No : 2005

W = 0.701 KG/M

P = 298.88 MM

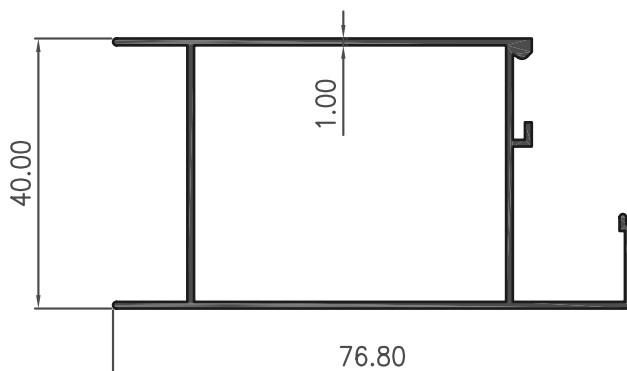

Section No : 2009

W = 0.646 KG/M

P = 298.49 MM

SWING DOOR

GROUP : 12.B

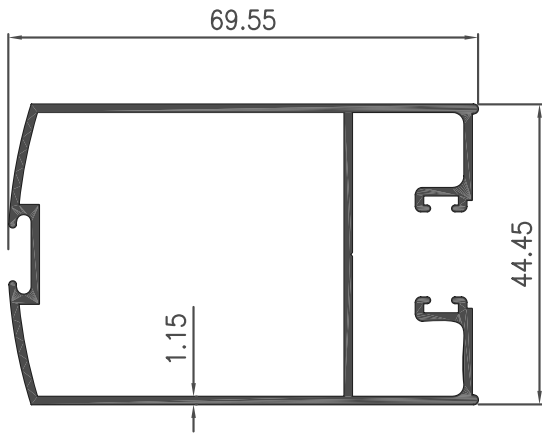

Section No : 2001

W = 0.882 KG/M
P = 368.52 MM

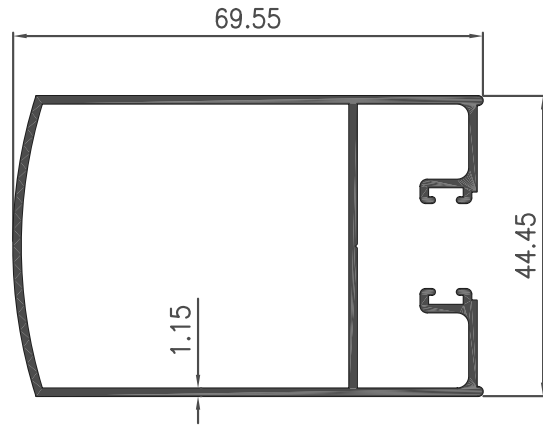

Section No : 2002

W = 0.845 KG/M
P = 356.82 MM

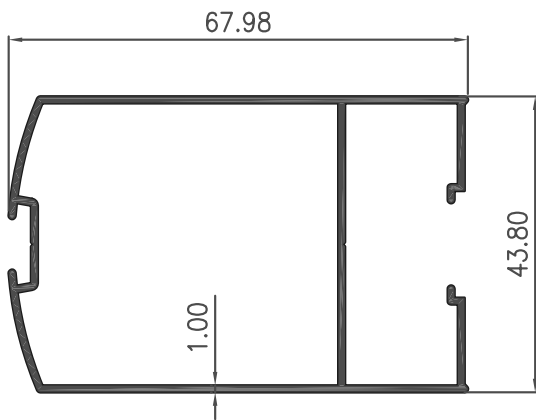

Section No : 2007

W = 0.688 KG/M
P = 329.95 MM

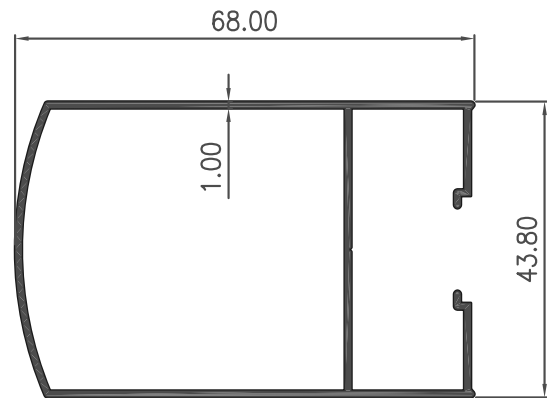

Section No : 2008

W = 0.661 KG/M
P = 315.18 MM

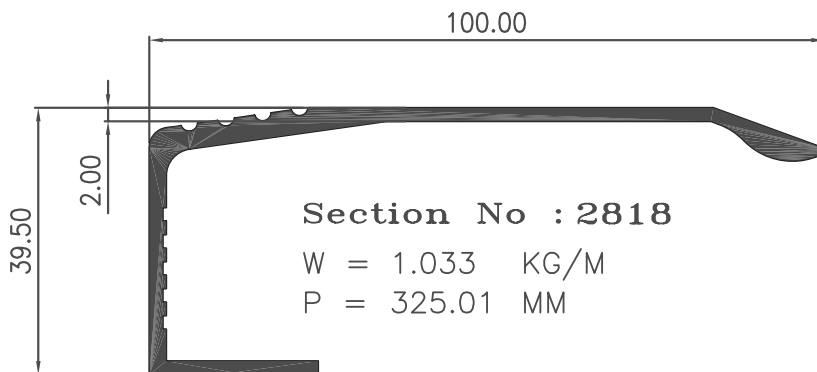

Section No : 2818

W = 1.033 KG/M
P = 325.01 MM

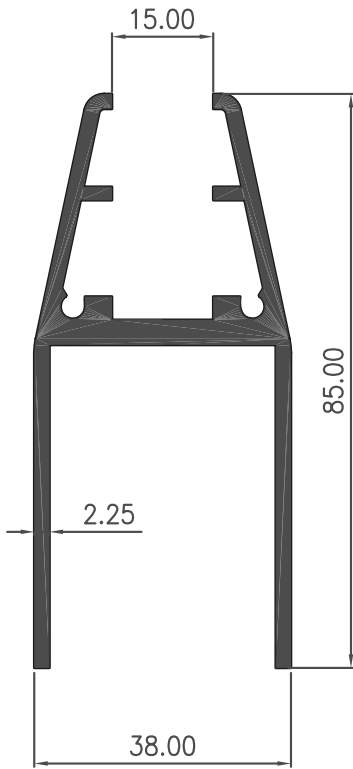

Section No : 6103

W = 1.536 KG/M
P = 440.75 MM

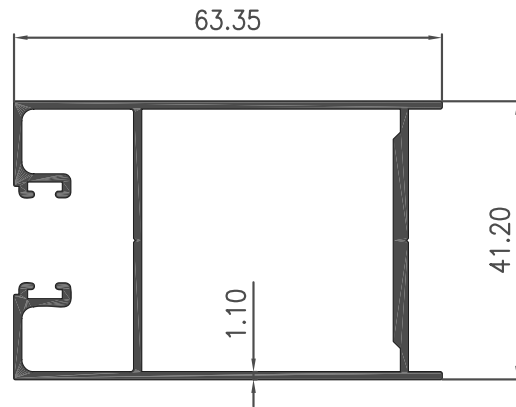

Section No : 2011

W = 0.852 KG/M
P = 346.40 MM

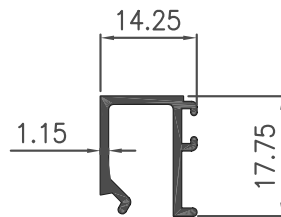

Section No : 2003

W = 0.173 KG/M
P = 110.90 MM

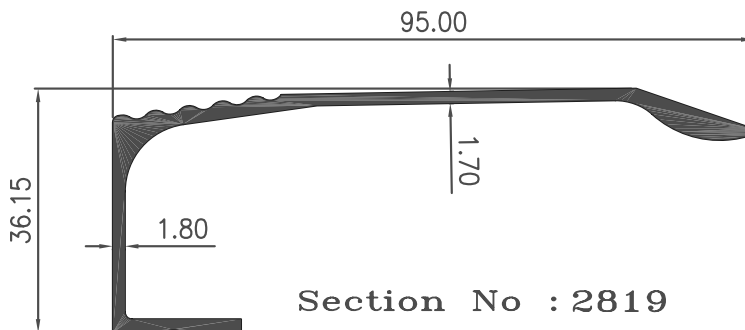

Section No : 2819

W = 0.825 KG/M
P = 288.17 MM