

ASSEMBLY DETAIL : SLIDING DOOR

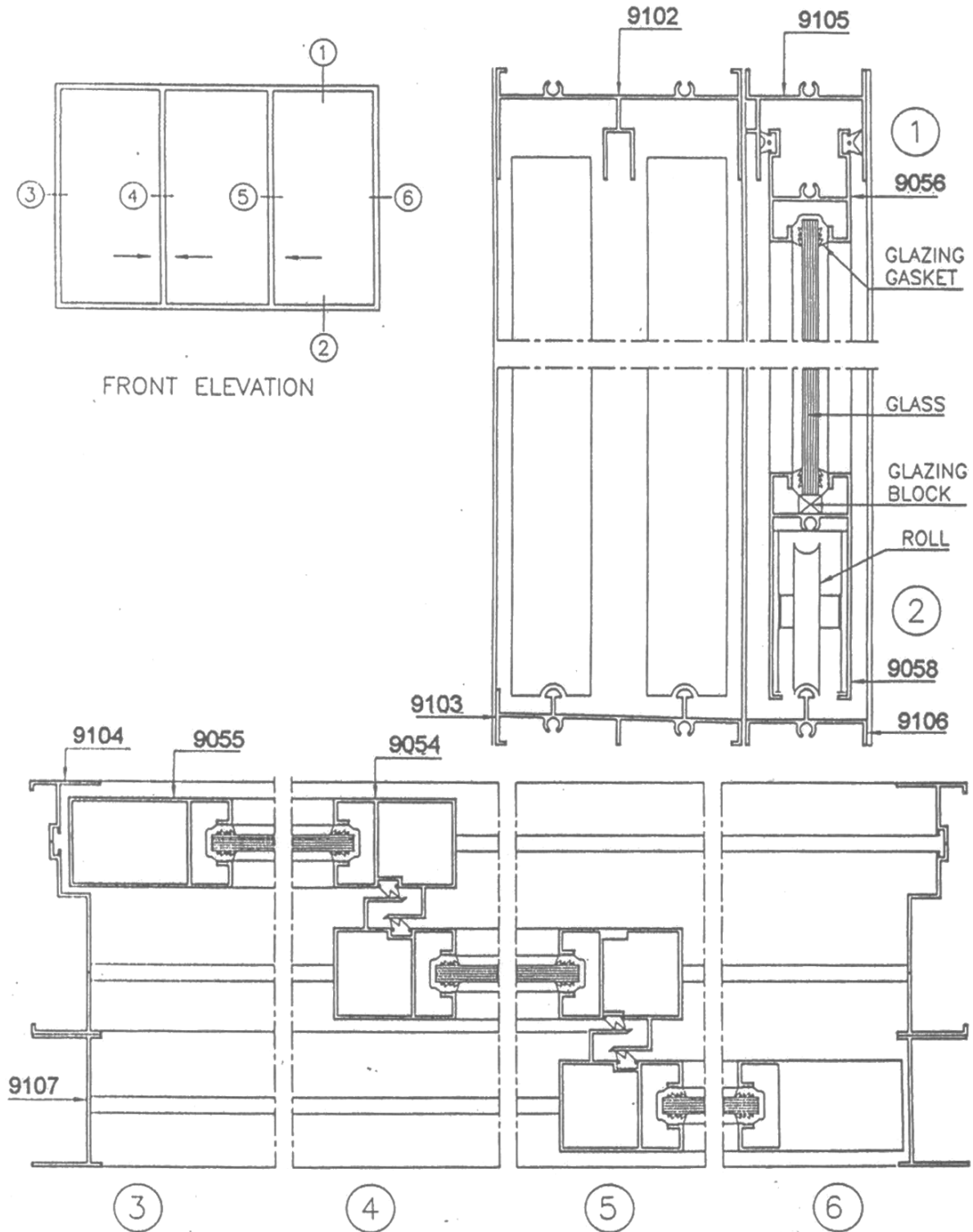

SLIDING DOOR

GROUP : 14.A

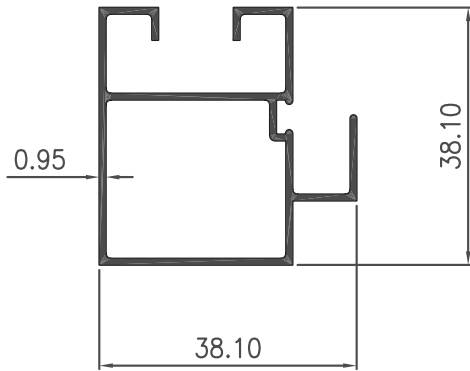

Section No : 9054

W = 0.461 KG/M
P = 251.46 MM

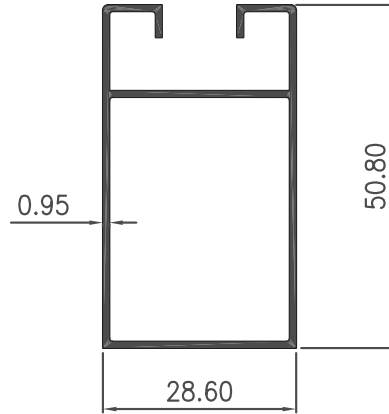

Section No : 9055

W = 0.460 KG/M
P = 229.30 MM

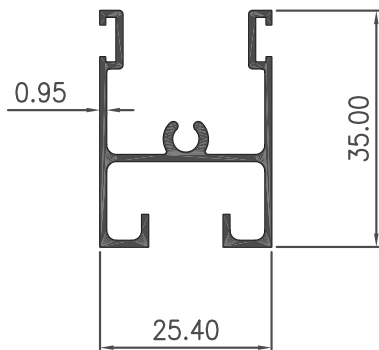

Section No : 9056

W = 0.376 KG/M
P = 267.22 MM

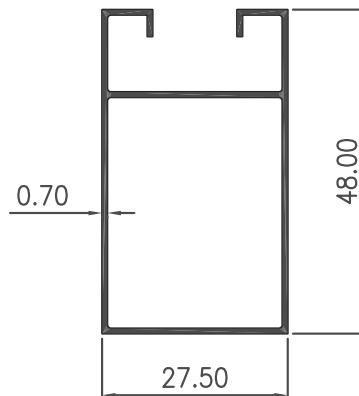

Section No : 9055A

W = 0.321 KG/M
P = 214.14 MM

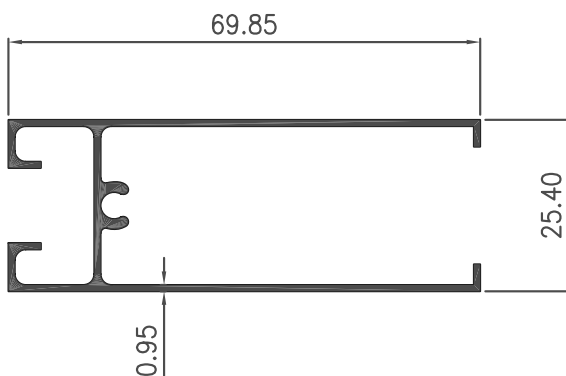

Section No : 9058

W = 0.536 KG/M
P = 388.57 MM

SLIDING DOOR

GROUP : 14.B

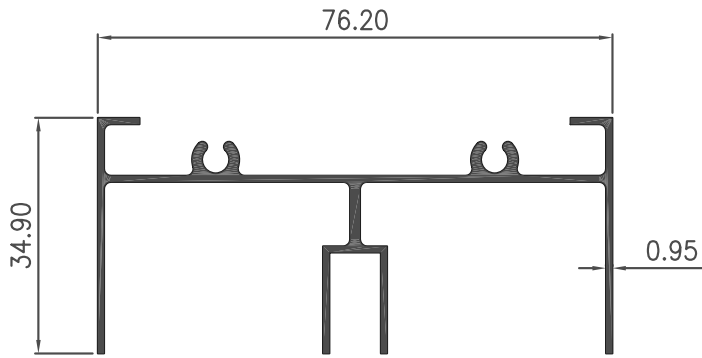

Section No : 9102

W = 0.590 KG/M

P = 437.06 MM

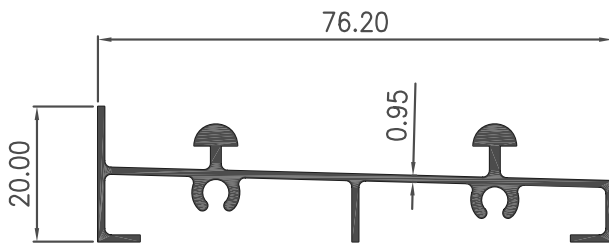

Section No : 9103

W = 0.460 KG/M

P = 320.20 MM

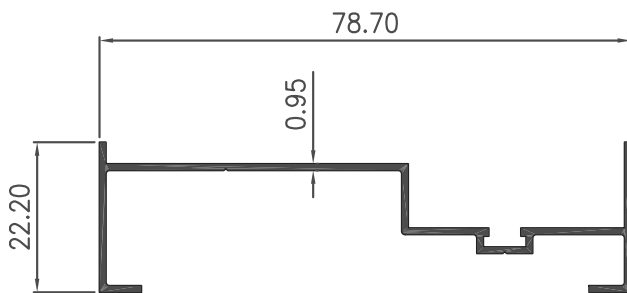

Section No : 9104

W = 0.383 KG/M

P = 297.46 MM

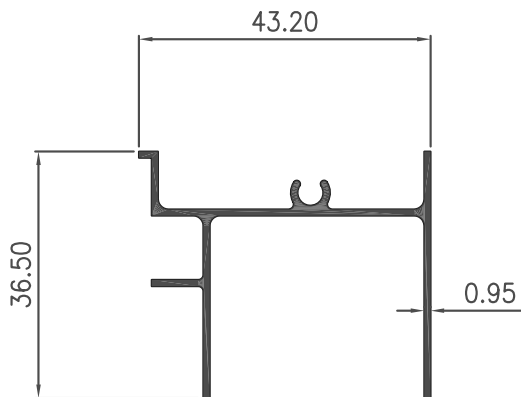

Section No : 9105

W = 0.351 KG/M

P = 256.01 MM

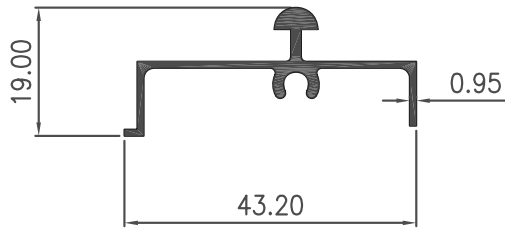

Section No : 9106

W = 0.269 KG/M
P = 160.87 MM

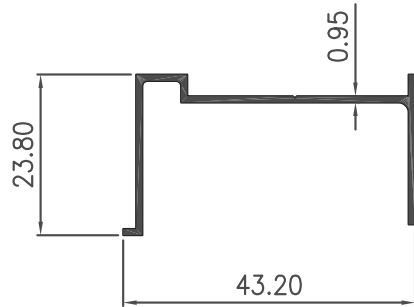

Section No : 9107

W = 0.235 KG/M
P = 181.86 MM

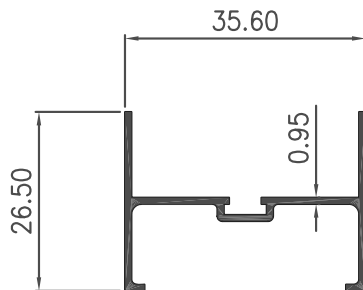

Section No : 9108

W = 0.254 KG/M
P = 193.28 MM

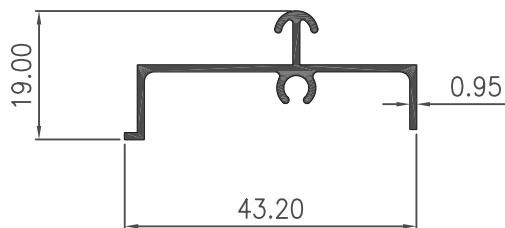

Section No : 9116

W = 0.234 KG/M
P = 170.01 MM

SLIDING DOOR

GROUP : 14.D

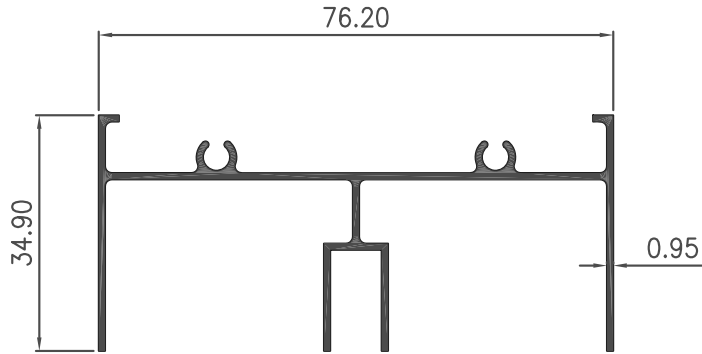

Section No : 9112

W = 0.578 KG/M

P = 424.20 MM

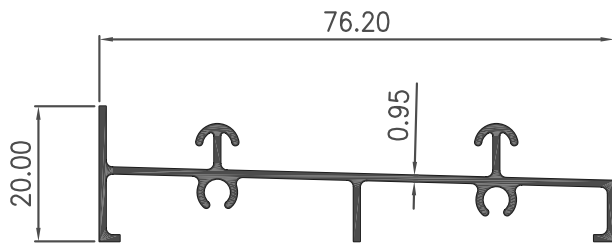

Section No : 9113

W = 0.449 KG/M

P = 318.65 MM

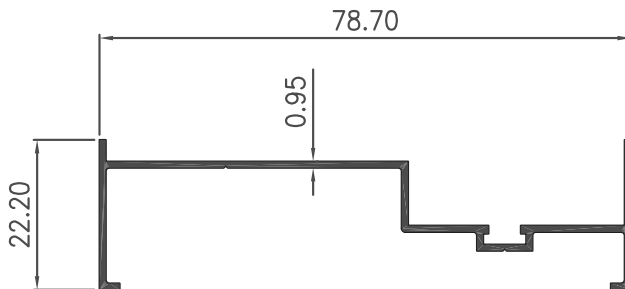

Section No : 9114

W = 0.367 KG/M

P = 284.66 MM

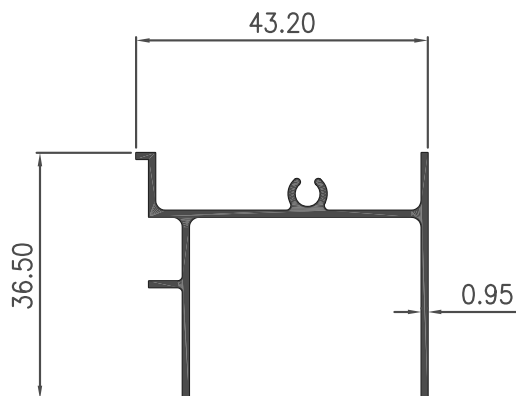

Section No : 9115

W = 0.346 KG/M

P = 253.18 MM